

# Community Crime Prevention Handbook

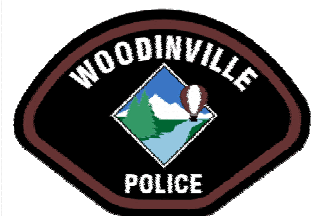

# IMPORTANT PHONE NUMBERS

Woodinville Police Department

17301 - 133<sup>rd</sup> Avenue NE

Woodinville, WA 98072

*Emergency*

*Call 911*

Non Emergency

206-296-3311

Operations Sgt. Scott Strathy

425-877-2278

Chief of Police Services Kent Baxter

425-877-2277

Block Watch Coordination

17301 - 133<sup>rd</sup> Avenue NE

Woodinville, WA 98072

Code Enforcement Officer Jason Burt

425-877-2285

Sheriff's Office

516 Third Avenue, Room W-116

Seattle, WA 98104-2312

*Emergency*

*Call 911*

Non Emergency

206-296-3311

Precinct 2

18118 73<sup>rd</sup> Avenue NE

Kenmore, WA 98028

*Emergency*

*Call 911*

Main Line

206-296-5020

# PUBLIC PARTICIPATION

**O**n the surface, the role of the police is straightforward: maintain order and enforce the law. Doing so effectively requires a partnership between people and their police. To create such a partnership, the King County Sheriff's Office relies on Community Oriented Policing.

## COMMUNITY ORIENTED POLICING

Community Oriented Policing is based on the recognition of some basic principles:

- ◆ **Professional success requires partnership.** Just as health care relies on the partnership between you and your doctor, law enforcement needs cooperation between you, your community and the police.
- ◆ **Partnerships require understanding.** The police must learn the community's problems, its point of view, its desires. The community must get to know the police - what they can do, how to work with them and how to talk to them.
- ◆ **A partnership must be ongoing.** If these things can be achieved, the community will see its needs met and feel safer. As a result, more people will report problems, work with the police to solve them, and the process will repeat.

That, in a nutshell, is Community Oriented Policing. It recognizes the need for understanding on both sides, and for a partnership to make it work.

## OUR APPROACH

Education is another important aspect of success. We want to involve the public in our business, meet you, explain what we do and why we do it, and ask for your opinions. Our training involves considerable education about cultural differences, the need for respect, and developing an appreciation of our role as helpers, not just patrollers. For citizens, education means learning how and why the police work, knowing your officers, and speaking up about the problems in your community.

## YOUR ROLE

Citizens can do four things to prevent crime and improve the quality of life in your neighborhood.

- 1 Be alert to suspicious activity, and call police immediately if you think a crime has happened or is about to take place. If you don't call, the police cannot respond.
- 2 Work with your local King County Sheriff's Office precinct or storefront, or your local police. You can provide useful information for preventing crime and crime-related problems.
- 3 Support efforts in your community to solve problems and attack the root causes of crime. Get involved with a Block Watch, neighborhood beautification project, or business watch.
- 4 Adopt the crime prevention philosophies and techniques in this handbook. Criminals look for easy targets; protect your home and your personal surroundings, and you will discourage crime.

---

# BLOCK WATCH: A KEY TO COMMUNITY CRIME PREVENTION

Block Watches are programs in which neighbors watch each other's property. Whenever you are home, you should be alert to what's going on in your neighborhood. A police officer may not recognize strangers in your neighborhood, but you and your neighbors will. You can then call police if the person is acting suspiciously.

**Reducing crime  
in our communities  
requires citizen  
involvement.**

## How does it work?

The program works through cooperation: neighbors watching out for neighbors. Neighbors know who you are and what car you drive. They may be the first to notice a burglar at your door or window.

Block Watches are not intended to be a substitute for police; they should not become patrols or vigilante groups. You are asked to report situations to police and let them handle it.

## How do I start a Block Watch?

First, call the crime prevention unit at your local KCSO precinct or police department. You can set a date and time for a meeting and arrange for an officer to attend.

Second, personally invite your neighbors and friends to attend. You can hold the meeting at your home, a club, a library, or even the precinct or police station.

Finally, stay committed by holding frequent meetings with your Block Watch members and staying alert in your neighborhood.

## What do I watch for?

Strange vehicles, suspicious persons, and people removing valuables from homes or vehicles are good indicators that something may be wrong. Also, listen for the sound of breaking windows or wood, or screams that indicate fear. Watch for people going door to door or driving around the neighborhood. Finally, watch for people being forced into cars, anyone shining a flashlight into a home, or people loitering.

If you see something suspicious, write down a description of the person and their vehicle (including make, model, color, and license number). Then call police (911) immediately. On the next page, you can find instructions for reporting a crime.

## What else can I do?

Exchange work and vacation schedules with a neighbor you can trust so you can keep an eye on each other's homes. Neighbors should also be able to contact you; be sure to give them home, work, and cellular phone numbers. If you know that your neighbor is away and you see an obvious invitation to a burglar, correct it. Close the open garage door and remove the newspapers from the doorstep. Collect their mail.

It takes effort to become acquainted with your neighbors and build the trust needed for a good Block Watch. The result is worth the effort.

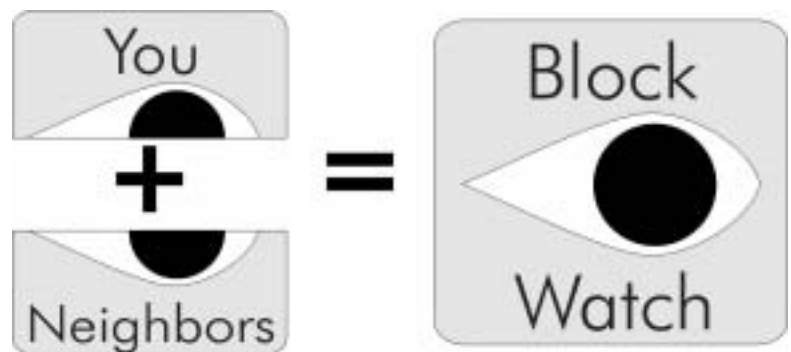

## EMERGENCY!

If a crime is happening or someone's life or property is in danger, call 911.

## CRIME STOPPERS

The Crime Stoppers program is one of the most successful examples of community policing in Washington. The program allows citizens who have information about a crime to anonymously call and provide police with information. If the information leads to an arrest and charge, the local Crime Stoppers program will pay up to \$1,000 to the citizen who provided the information. In King County call (206) 343-2020.

## VANDALISM

Statistics have shown that crime rates rise significantly in neighborhoods where windows are broken, sidewalks and vacant buildings are littered with garbage, and graffiti is allowed to stay on buildings and walkways.

When you and your neighbors ignore vandalism, you send out a clear message that you don't care about the neighborhood. One broken window or a wall covered with graffiti will lead to similar acts of vandalism.

Fighting vandalism is one job that neighborhood residents can do more effectively than anyone else. Few police departments have the resources to track down those who illegally dump trash or deface communities. Neighbors can immediately spot and eliminate vandalism and graffiti through neighborhood cleanup projects.

### How to stop vandalism

To stop vandalism from evolving into an even more serious problem, you and your neighbors must be willing to do something about it. In many neighborhoods, acts of vandalism may be isolated events. Nevertheless, if they are left unattended, they may become a major concern for your community.

Once you and your neighbors are aware of acts of vandalism, you can be on the lookout and use Block Watch techniques (page 5) to foil potential vandals. When neighbors act as the "eyes on the street" they notice suspicious activity and report it to the police (911). If even a few criminals are caught in the act and reported to the police, the word will spread that your neighborhood is not a good place to commit a crime.

## HOW TO REPORT A CRIME

Law enforcement needs your help in reporting crimes. Be alert wherever you are and learn to recognize crime. When you see or hear something that might indicate that a criminal act is being committed, don't hesitate to call police (911).

When you are reporting a crime, stay calm and state the problem. Give the address where the emergency is occurring. Remember to give the full address and the nearest cross street.

It is important to be able to describe the offender to police after the offense happens. Police need to know the suspect's race, sex, age, height, weight, build, complexion, hair color, eye color, clothing, and identifying marks such as tattoos. Remember though, as important as this information is, don't risk your own safety to obtain it. If possible, keep the suspect from knowing that you have seen them.

When you call the police, let the dispatcher control the conversation. Answer all questions. If you wish to remain anonymous, give your name to the dispatcher and then request anonymity. The police will call you later if they need more information.

# OPERATION IDENTIFICATION

Operation Identification is a part of the Block Watch program that is specifically designed to discourage theft and provide a means of easy identification if your property is stolen or lost. Through the program, you mark your property with your driver's license number or Washington State identification number and create an inventory.

Identifying your property serves many purposes. First, it may discourage thieves; marked property is hard to dispose of because it is easier to trace. Second, if property is stolen and recovered, proper identification makes it easier for police to return it to its rightful owner. Finally, having marked and inventoried property can ease the process of filing insurance claims after a loss.

## How do I participate?

Check with your local KCSO precinct or storefront, or your local police department. They may have an engraver you can borrow. Hardware stores and many King County libraries also rent or loan engravers. The engraver marks wood, metal, and plastic.

**Marked property helps prosecute criminals. Police can't file charges if they can't positively identify the property as belonging to someone else.**

Your local crime prevention officer can give you inventory forms to record your marked property. Keep one copy for yourself in a safe place (e.g., a safe deposit box) and store a second copy with a friend or neighbor. Don't store the list on your computer; it may be stolen as well.

After you engrave your property and complete the inventory, the officer will give you "Operation ID" warning stickers to display on your home to deter thieves. If sixty percent of the homes in your Block Watch participate in the Operation Identification program, you may purchase the large "Block Watch" signs for your neighborhood.

**If recovered property can't be traced to its owner, it is often destroyed or auctioned.**

## How do I mark my property?

You should mark all items of value with your driver's license number or the number on your Washington State identification card. Don't use your Social Security Number.

Mark your items near the serial number. Be sure to mark on the frame or another permanent part of the item. Do not mark a part that can be easily removed or replaced.

Here's how to mark items:

WA SMITH455CM DL (driver's license)

WA SMITH455CM ID (identification card)

## What if I can't mark an item?

Some items, such as jewelry, cannot be marked because they are too small or marking would ruin the value. In such cases, photograph or videotape the items. Be sure to focus on identifiable points. Store the photos or tape in a safe place. Keep appraisals in a safe place as well.



Most pawnshops are required to check property for identification.

# HOME SECURITY

**T**here are many ways to secure your home and protect yourself and your belongings from crime. Time, noise, and light are a burglar's worst enemies. With a little effort, you can create deterrents to property damage or loss. If you have questions, don't hesitate to contact your local crime prevention officers.

Use the picture below to think about areas of your house where you can improve safety, and then use the techniques in this book to take action. Your first consideration should be what security features your home has now, and how they can be used more effectively. Most burglaries take place because people did not use existing safety measures such as door and window locks. Criminals look for easy targets, so prevention starts with you.

**Criminals look for easy targets, so prevention starts with you.**

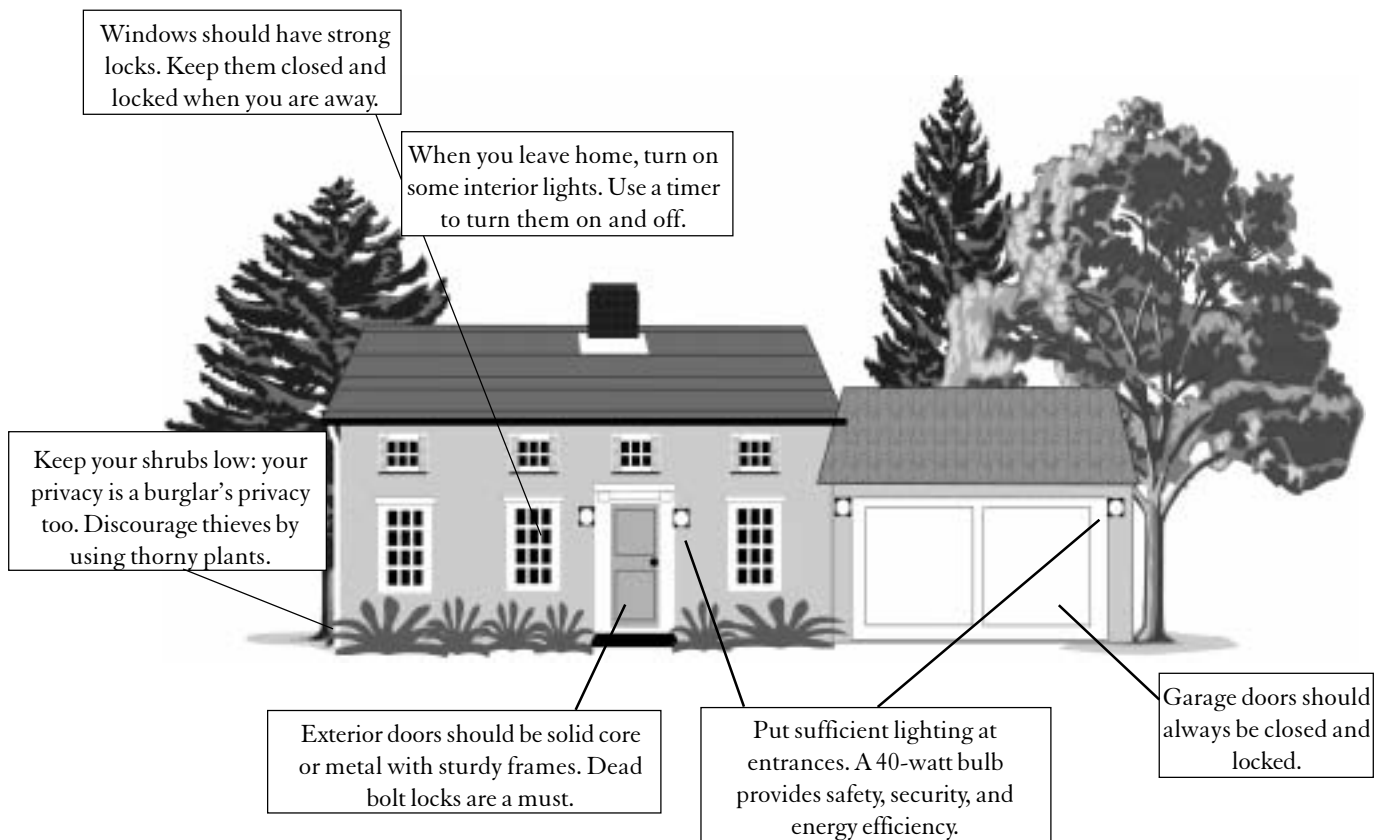

# Doors & Locks

## DO YOU HAVE THE RIGHT DOOR?

There are three types of doors available: hollow core, solid wood/solid wood core, and metal.

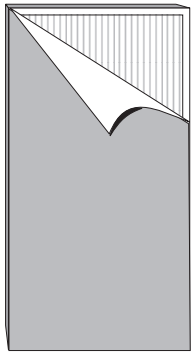

**Hollow Core Door**

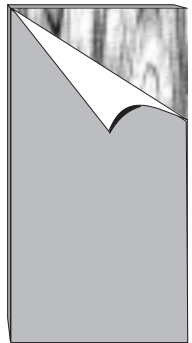

**Solid Core Door**

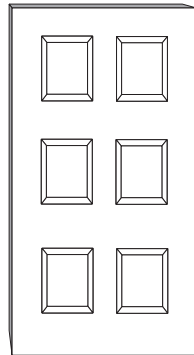

**Metal Door**

### Hollow Core

Hollow core doors are made from thin sheets of wood veneer glued over a wood frame with a cardboard insert.

### Solid Wood/Solid Wood Core

These doors are made from solid wood or a wood veneer that is glued over a solid wood core.

### Metal

Metal doors are constructed with a thin metal sheet that is glued over a solid wood core.

### The Right Door for Your Needs

For exterior doors, including doors from your home to your garage, you should use solid wood core or metal doors. The doors should be at least 1¾ inches thick, and should not have glass or thin wood panels.

Hollow core doors are good for closets or other interior uses.

## PROBLEM DOORS

The best way to deal with problem doors is to replace them with more secure doors. If you can't replace the door, consider taking the following steps.

### Sliding patio doors

Sliding patio doors should have the type of locking mechanism that vertically secures the top and bottom of the door to the track. If the only lock is from the handle to the wall, then additional steps should be taken to secure the door.

Keyed locks that attach to the top and bottom of the sliding door can be installed. Locks that can be hand-tightened may be safer in a fire; check with your local fire department.

A less expensive way to secure the door is to place a snug-fitting wooden dowel or other piece of wood into the track to block the door from opening. This method, however, is easily defeated from outside with something as simple as a paper clip. Factory-made bars that mount on the wall side of the doorway and swing down to lock the door in place (Charlie Bars) are another option. These bars are not as secure as locks at the top and bottom of the door.

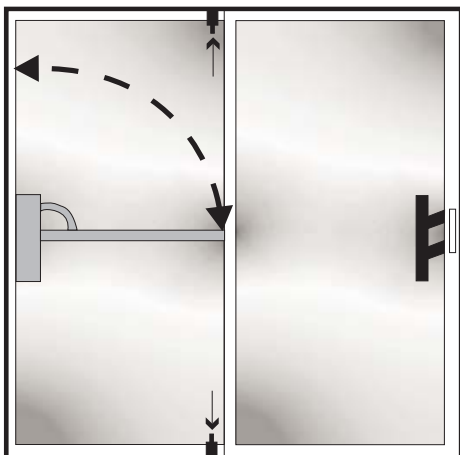

## Pet Doors

Although pet doors are convenient for pet owners, they can be an easy point of entry for a burglar. Some burglars are small enough to fit through pet doors, and others enlist the aid of a smaller person to enter the home and unlock a door or window for them.

## Garage Doors

Garage doors are another weak link in home security. If you use an automatic door opener, change the internal code from the factory setting. Consult the owner's manual for instructions. Since garage doors can be easily defeated, you must use a solid wood or metal door with a dead bolt and strike plate between the garage to the house. When you leave on vacation, consider unplugging the door to prevent accidental opening.

## Storm Doors

Storm doors are not security doors. They provide only minimal privacy protection and cannot be relied on for any security. They are designed only for protection from the weather.

# DOOR HINGES

Exterior doors should not have hinges with the hinge pins on the outside. If the hinges are on the outside, you should replace the door or secure the hinges with a non-removable pin. You can purchase hinges with non-removable pins at most hardware or home improvement stores.

# VIEWERS/PEEP HOLES

A viewer (peep hole) allows you to see who is on the other side of your door. All exterior doors should have one installed at eye level. You can purchase viewers at most home improvement stores.

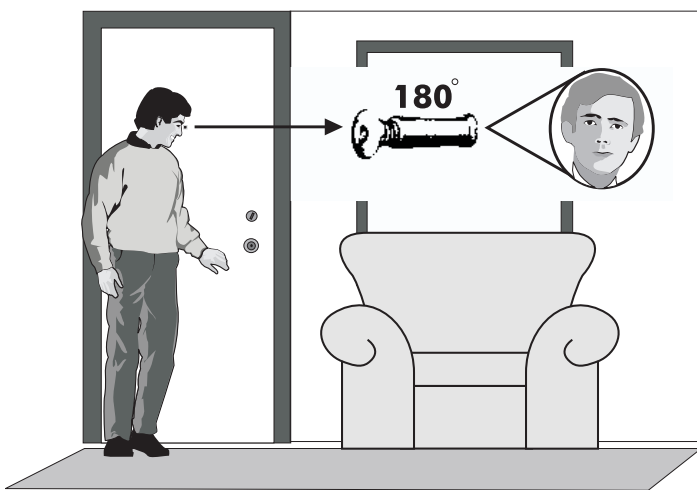

## Fire Safety Alert!

**When you're at home, leave a key in a double cylinder dead bolt. You'll need a quick escape in a fire or other emergency.**

# HOW TO SECURE DOORS THAT HAVE GLASS PANELS

You have three options for securing outside doors with glass panels.

1. Install a clear, unbreakable polycarbonate panel over the glass on the inside of the door or use the panel to replace the existing glass. Fasten the panel securely on the inside of the door.
2. Install grated wire mesh, a wrought iron grille, or decorative wire grate over the glass. Be sure intruders would not have access through the grates to your locks.
3. Install a clear anti-penetration protective film over the glass.

## TYPES OF LOCKS

Locks are your first line of defense against intruders. There are a few types of door locks, and some are better than others at deterring burglars and preventing crime.

### Door Knob Locks

You can purchase two types of door knob locks: spring latch and dead latch.

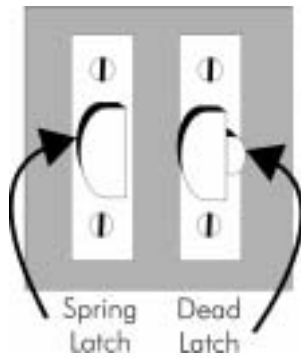

The dead latch locks provide slightly more security than spring latch locks. Nevertheless, these locks offer only minimal protection, and should be used on interior doors. If you use a door knob lock on an exterior door, it should be supplemented with a dead bolt lock.

### Dead Bolt Locks

Dead bolt locks offer the best protection, so they should be used on all exterior doors. Be sure that the locks you use have bolts that extend at least one inch into the wall, and that the locks are made of solid metal with no exposed exterior screws. Some dead bolt locks also offer free-spinning collars; these prevent intruders from removing the cylinder with a wrench or vice grips.

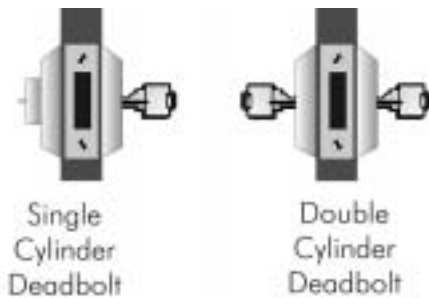

Dead bolt locks come in two types: single cylinder and double cylinder. Single cylinder locks operate with a key from the outside and a thumb lever on the inside. Double cylinder locks use a key both inside and out. Double cylinder locks offer better protection; if a burglar enters the house through a window, he or she cannot open the door without a key. The burglar would have to exit through the window, limiting the objects that can be removed. Double cylinder locks can pose a fire safety hazard, so you must consider your options and choose the best solution for your home.

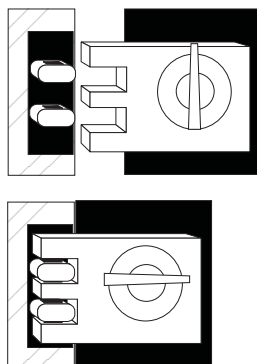

Vertical Deadbolts

Vertical dead bolts are another lock option; they are used primarily to secure double doors. The lock is secured to its mating plate with pins that make it difficult to pry. Double doors are not as secure as a single door because you cannot secure the lock to the wall frame. Vertical dead bolts also come in single or double cylinder models.

Dead bolt locks must be locked when you leave your home. If you pull your door shut and walk away, the door is not locked.

### Security Strike Plates

In addition to the dead bolt, you should install a security strike plate on the door frame. The strike plate is heavy metal and is anchored to the door frame with 3 1/2 inch screws that secure it to the wall stud. The plate and screws make it more difficult for a burglar to force the door open. Check your existing doors; many contractors do not use long screws when installing strike plates.

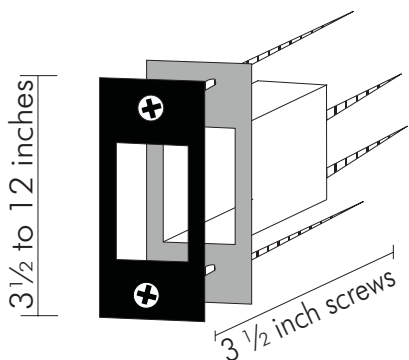

## DOOR FRAMES

Even if you use solid core doors and dead bolt locks on the entrances to your home, you may still be vulnerable. Burglars often use a technique called spreading. To do this, they insert a wedge between the door frame and the wall. The frame bows under the pressure, allowing the intruder to enter your home.

If you install doors, be sure that you place solid blocks between the frame and wall at the top, bottom, and middle of the door.

To strengthen existing frames, install large (3-4 inch) screws through the doorstop strip and frame. These screws should extend into the wall studs. The screws will pull the door frame and doorstrip tightly against the main wall.

## EXTERIOR LIGHTING

Good exterior lights are one of the best burglary deterrents available because they keep would-be burglars from concealing themselves in the dark. There are several types of lights to consider, including the following.

- ◆ High pressure sodium or mercury vapor lights attached to timers are very effective tools.
- ◆ Passive infrared sensors turn on lights if they detect movement.
- ◆ A forty-watt light at each entrance, including the garage, will provide you with both safety and security.

## LANDSCAPING

The shrubs that provide you with privacy also give a burglar a place to hide. Prune bushes down to two feet or trim trees up to at least four feet. Avoid having trees or tree branches near windows. If you want privacy, consider planting shrubs that have large thorns.

## HOUSE NUMBERS

Install your house numbers so that the police, fire, and medical services can readily identify your house, both in daylight and darkness. Be sure the color of your numbers contrasts with your home's color, and that lights do not cause glare or reflections that make the numbers hard to read. If your house has sidewalks or curbs, paint the numbers on the curb (check your local regulations before painting).

## OTHER SECURITY DEVICES

### Door Wedges

A wedge is inexpensive, and when two steel pins are inserted into the floor, the door may be opened only a few inches. The pins prevent the wedge from slipping if force is applied to the door from the outside. Wedges are useful for bedroom doors because they can slow down intruders.

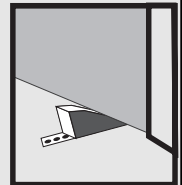

### Chain Locks

Many homes also have chain locks, and people often use these as night latches. Chain locks are usually mounted with short screws and have weak chains. They are not recommended as a primary security device. All exterior doors should be secured with dead bolt locks.

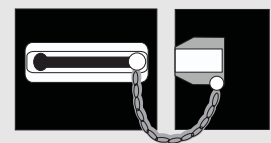

---

# Windows

## SECURING YOUR WINDOWS

Many burglars may try to enter a house through a window, either by opening it or breaking the glass. Often, they will open the window catch with a pry bar or a sharp, pointed object. Other burglars will try to remove a pane of glass by removing the glazing spline or putty with a knife. Still others may break the glass, reach in, and release the window catch. You can protect your home by reinforcing the glass in the windows and by making windows more difficult to open.

### Fire Safety Alert!

Windows can provide a fast exit in a fire or other emergency. When you secure your windows against burglary, be sure to plan for good emergency escape routes. Your local fire department can offer recommendations.

## SECURE WINDOW GLASS

Normal window pane glass is about 1/8 inch thick and easily broken. You should consider replacing this glass with pane glass, which is thicker and stronger, or tempered glass, which is stronger and will not cut someone who breaks it. The following glasses and plastics are arranged in descending order of break resistance.

### Highest Resistance (Unbreakable)

- ◆ Polycarbonate plastic vinyl-bonded laminated glass, 1/2 inch thick or more
- ◆ Acrylic plastic sheets, at least 3/8 inch thick

### Medium Resistance (Vandal-Resistant)

- ◆ Wired glass, 1/4 inch thick
- ◆ Laminated glass, 1/8 inch thick
- ◆ Acrylic plastic, 1/8 inch thick, depending on specific chemical characteristics

### Medium Resistance (Break-Resistant)

- ◆ Plate glass, 1/4 inch thick
- ◆ Conventional float or sheet window glass, more than 1/4 inch thick
- ◆ Tempered plate glass, at least 1/8 inch thick

### Shatter-Resistant Window Film

You can also secure a window by placing transparent polyester film on the inside glass. The film holds the glass together if the window is broken. Film is especially useful for sidelights and windows that could offer access to inside doorknobs and catches.

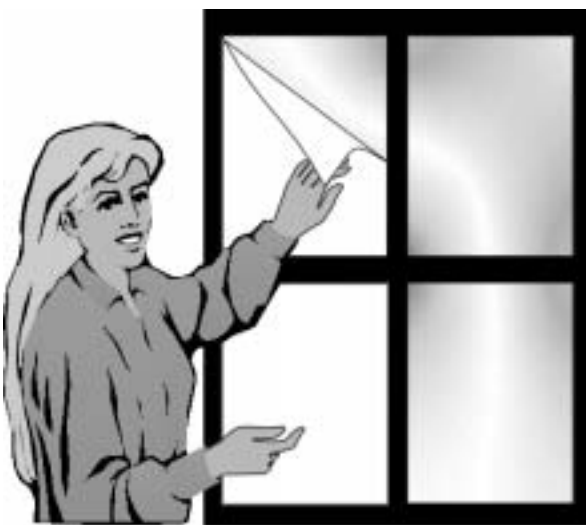

## Heavy Duty Screens

Heavy duty security screens with a minimum of 3/4 inch times number 9 wire mesh can protect vulnerable areas. If possible, install the mesh on the inside of the window. If you must install the mesh on the outside, use one-way screws or a 3-inch lag bolt to make removal more difficult.

## Ornamental Grillwork

Grillwork can protect windows that are vulnerable, but they are not recommended if you are using these areas as a fire exit. Check your local fire codes before installing grillwork.

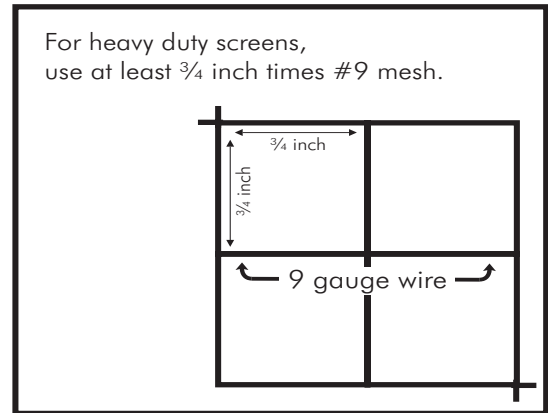

## DOUBLE-HUNG WINDOWS

There are several ways to secure a double-hung window. The simplest method is to place a snugly-fitting 3/4-inch dowel on both sides of the window, above the bottom frame.

A second option is to drill a hole through the sliding portion of the window halfway into the stationary portion. Then, place a strong nail into the hole. You can place another hole about four inches above the first so that you can open the window for ventilation but still leave it secure.

A final option to install keyed or twist locks above the sliding portion of the window. If you use keyed locks, keep a key nearby in case you need an emergency exit.

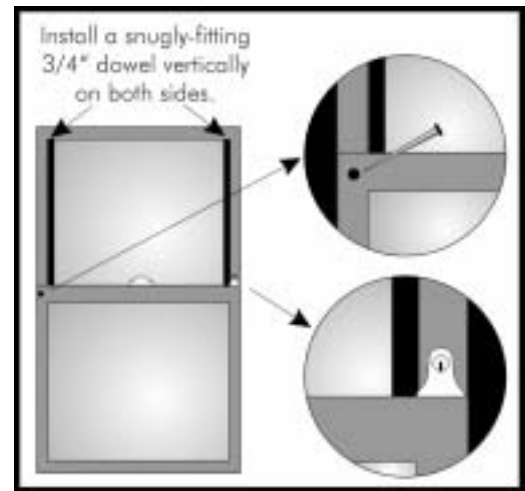

## SLIDING WINDOWS

If the window slides on an inside track, place a snugly-fitting metal rod or wooden dowel in the bottom track to keep the window from being forced open. Charlie Bars serve the same function (please see page 9). The rod or dowel should be a 1/2-inch diameter; if the span is over three feet, use a 3/4-inch diameter rod.

Some windows can be secured with a pin in the bottom track. Close your window and drill at a downward angle through the inner frame and halfway into the outer frame. The hole should be slightly larger than a nail. Slide a pin or nail into the hole. You should not do this with insulated windows.

Many sliding windows have considerable space between the window and the top of the track. This allows the window to be removed easily, making repair simple. Unfortunately, it also makes a burglar's task much easier. Keep your windows in their tracks by installing screws or spacers in the upper track of the windows.

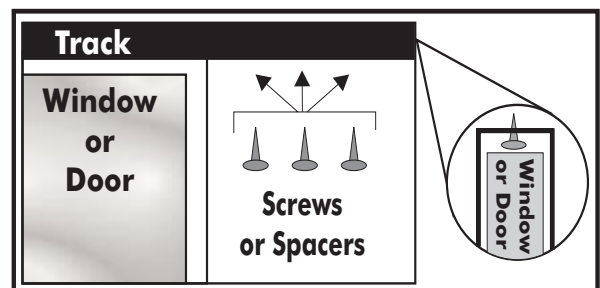

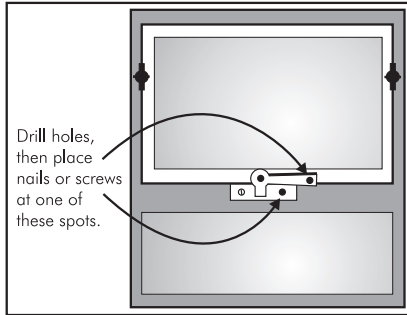

## PUSH-OUT WINDOWS

Push-out windows provide ample opportunity for a small person to enter your home. To secure them, drill a hole through the locking portion of the handle and into the frame. A pin can then be inserted to stop the opening action. A screw offers a more permanent solution, but can also pose a fire safety hazard.

## LOUVERED WINDOWS

Although louvered windows may be very attractive, the panels are easy to remove and they cannot be properly secured. The best option is to replace louvered windows.

# Alarms

## SELECTING AN ALARM SYSTEM

Selecting an alarm system or alarm system company can be a daunting task. Although your local Sheriff or Police Department cannot recommend a specific company, we can offer a few tips to guide you in making a decision.

### CONSULT THESE AGENCIES BEFORE BUYING AN ALARM SYSTEM

Washington State Burglar  
and Fire Alarm Association  
1-800-248-9272

Your Local Better Business Bureau  
Your Local Chamber of Commerce

Washington State Attorney  
General Consumer Protection  
Division  
1-800-551-4636

Your Local Sheriff/Police  
Crime Prevention Unit

**1** Consult several reputable alarm system companies. You should get competitive quotes and information about what services are offered. Obtain written proposals and estimates that include the company's recommendations and all associated cost factors, including permits or inspections if required.

**2** Ask the company representatives several questions, including the following.

- ◆ Are they and the installers licensed and bonded?
- ◆ Do they subcontract or use company installers?
- ◆ Do they carry insurance to cover damage done to your property during installation?
- ◆ Does the system have a battery backup? If so, how is the battery recharged, and how often does it need replacing?
- ◆ What is the written guarantee on parts and labor and the length of the warranty?
- ◆ Are there service charges after installation?
- ◆ What is the policy on false alarm billings?
- ◆ What is the policy on cancelling alarm services? Is there a minimum contract term?
- ◆ Who owns the system?
- ◆ Can you get an unmonitored system at the same price?

---

**3** **Conduct research at your local library to learn about hard-wired and non-wired systems**, as well as the types of sensors that are available. Keep in mind that most systems can be bypassed by cutting the phone lines. Consider wireless backups and “cloning” to another close phone line in case your line is cut by burglars. Ask about “panic” alarms and where the siren or noisemaker will be installed. You may want to consider portable key pads.

**4** **Decide if you need a local alarm or monitored system.** Local alarms activate a bell, siren and/or strobe light outside your home or business. Monitored systems have a contract with your alarm company to monitor your alarm system 24 hours a day via your telephone line. They will call police or fire services if your system is activated. Ask what their response process and response time will be.

**5** **Make sure your alarm system and any planned installation is in compliance with local ordinances.** Most jurisdictions now have or plan to have ordinances that govern the number of false alarms you may have before fines are assessed. You are responsible for all false alarms and compliance with ordinances and the permitting process. When your alarm is installed, insist that the alarm company teach you to correctly operate the system, including panic codes.

**6** **Consider having fire and smoke sensing systems integrated into your alarm system (they are required in all new homes).** They will not only cut your losses in case of a fire but also may cut your insurance costs.

**7** **Be sure your system alarms** for a short period of time and then shuts down. The alarm should then rearm itself for the next intruder or attempted intrusion.

**8** **Contact prior and/or current users** of the alarm company and ask their opinion.

## **IF YOU HAVE A SECURITY SYSTEM**

**Prominently display the decals** supplied by your alarm company on your doors and windows to deter criminals.

**Be sure your alarm system has a reliable battery back up.** You should test batteries at least every six months, replacing them if necessary. To remind yourself, test your alarm system when you test your smoke detectors.

**Be sure you update your security company** at least annually with your information, addresses of respondents, phone numbers and vacation plans.

---

# Leaving Home

## PREPARING FOR VACATION

### BEFORE YOU LEAVE

If you have any questions about your home security or security on your trip, call your local Sheriff or Police Department Crime Prevention Officer.

To reduce the chances of burglary while you are on vacation, you should complete the home security upgrades noted in this book. Repairs on locks, doors, and lighting, as well as the personal property inventory and Operation ID should all be done before you leave.

In addition, you should take the following steps. Photocopy this page and use it as your vacation checklist.

1. Notify responsible neighbors or relatives of your itinerary and contact numbers. Ask your Block Watch Captain to coordinate house checks. Choose a trusted friend or neighbor to be your representative while you are gone.
2. Notify your local Sheriff/Police Department or storefront and alarm company about your schedule and leave your local representative's numbers as well as your away contact numbers.
3. Arrange to have the Post Office stop delivering your mail until you return, or arrange for it to be picked up regularly by your representative.
4. Cancel all normal deliveries such as milk and newspapers, or arrange for your representative pick them up.
5. Ask your representative to help you make your home look occupied. He or she should mow your lawn or shovel your walk, collect any brochures or information left on your door or in the yard, and open and close your drapes.
6. Do not leave any easily stolen objects such as power mowers, garden hoses, lawn chairs, and bicycles in your yard.
7. Hide all valuable or irreplaceable items, (e.g., jewelry, computers, firearms, important papers, or checkbooks) in a safe place such as a safety deposit box or home safe. You could also leave them with a trusted friend or relative (check your insurance coverage). Make sure your home inventory is up to date and keep copies in separate safe locations.
8. Unplug your garage door opener so that your garage doors are secure. Consider placing a padlock through the track for extra security.
9. Consider moving your motor vehicle(s) to a different location until you return, or have your representative move them regularly to make it appear as if you are home.
10. Avoid publicity about your trip until you return.

Consider setting your lights, radios, and televisions on reliable electronic timers so that your home will look and sound occupied while you are gone.

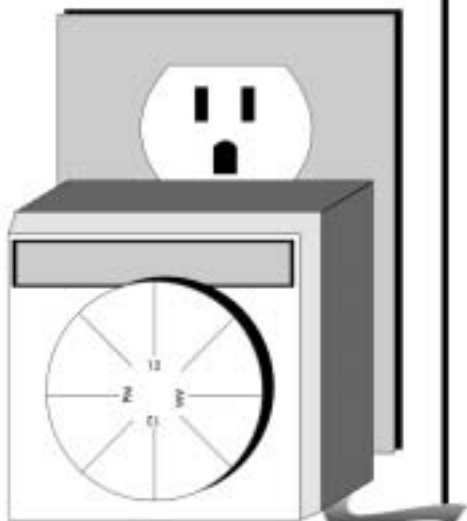

# VEHICLE and BICYCLE SECURITY

**Y**ou can do a lot to prevent a vehicle theft. Have you read how easy it is for a car thief to enter a locked vehicle? The truth is that in many cases, the keys were left in the ignition. You need to remove the opportunity for a crime to take place.

## VEHICLE SECURITY

### Lock Your Car

Lock all doors and windows to avoid being a target.

### Don't Leave Your Car Running

Leaving your car running and unoccupied may seem convenient, especially to warm the car in winter, but it's an invitation to a thief.

### Install Anti-Theft Devices

Installing an anti-theft device such as a locking device for your steering wheel or ignition cut device tells a potential thief that you are protecting your vehicle. A car alarm is a deterrent and will detect any attempt at an intrusion and help protect the car's contents.

### Remove Valuables

Remove all items of value or place them in the trunk of your vehicle. Cell phones, briefcases, loose change, and tape or CD players are obvious targets for criminals.

### Be Smart When You Park

Park in a safe, well-lit area where it would be difficult for someone to tamper with your vehicle. At home, use your garage or park as close to your residence as possible, preferably off the street.

### Protect Your Registration

Keep your vehicle registration in a secure location in the car. Keep your title at home or in a safe deposit box.

### Protect Yourself in Your Car

Never pick up a hitchhiker, it's just not safe. Remember to keep your doors locked at all times. If someone approaches your car, do not open the door or window; if possible, drive away.

## FACTS ABOUT AUTO THEFT

### Auto Theft and Larceny

Police refer to auto theft as motor vehicle theft. If a person takes your car without your permission, it is considered motor vehicle theft. That person may be punished by up to five years in prison.

If someone enters your vehicle and steals the contents (e.g., a tape deck or wallet), police refer to the case as a Larceny TFA (taken from auto).

### Who Steals Cars?

Car thieves are often amateurs, under the age of 20, who will take a car for the thrill of joy riding.

Professionals who steal cars may sell them with a phony registration or dismantle them in a "chop shop" and sell the parts.

### What Cars are Stolen?

Any type of vehicle can be a target for thieves.

## USE YOUR BLOCK WATCH

Practice good Block Watch techniques by quickly calling the police when you observe any suspicious activities in your community. The police want to know when you see a stranger or an unusual vehicle. Your call may prevent a crime from happening in your community.

## PROTECT YOUR BICYCLE AGAINST THEFT

A bicycle can be stolen from just about any place, but simple precautions can deter would-be bike thieves.

### **Start by Locking Your Bicycle**

Most bikes that are stolen were not locked. Always lock your bike securely, whether you're gone for a few minutes or a few hours. Use a "U-lock," which secures both wheels and the frame to a stationary object such as a post, tree or a bike rack. For extra security, add a chain or cable with a good case-hardened padlock.

### **Keep Good Identification Records**

Record the serial number of your bike and keep it, along with your sales receipt and a picture of your bike, in a safe place at home.

Mark your bike with an engraver to deter thieves. Engraving also helps police to identify a bike and return it to the rightful owner. You can find more information about engraving on page 7.

Finally, ask your local schools about bicycle registration programs.

**Report a theft to the police as soon as you can.**

**Remember to always wear your helmet.**

It's the law.



# PERSONAL SECURITY

**I**ncidents of violence can occur anywhere at anytime. Trust your instinct that something may be wrong, and use these guidelines to reduce your vulnerability. Remember though, whether or not you choose to use the options, no one has the right to harm you.

## SECURITY IN YOUR CAR

- ◆ Keep car doors locked and windows closed at all times.
- ◆ If you have car trouble, raise the hood and stay in the vehicle. If someone offers assistance, either roll the window down just enough to talk to them or write them a note. Ask them to stop at a phone and call the police.
- ◆ Do not stop to help a stranger in a stalled vehicle. Go to a safe place and report the stalled vehicle to police.
- ◆ Don't pick up hitchhikers.
- ◆ If someone tries to break into your car while you are in it, honk the horn in short and long bursts and try to drive away.
- ◆ If you are being followed, don't go home. Drive to the nearest police or fire station or an open gas station - any place with people around.
- ◆ Park in well-lit areas that are close to your destination.
- ◆ Always have your keys ready to unlock the car door and enter without delay. You can appear vulnerable if you look for your keys as you approach your car.
- ◆ Carry a small light on your key chain to see the car or house door lock easier.



**Above all, be observant and aware of your surroundings at all times.**

- ◆ Keep your car maintained. Your gas tank should always be at least half full.
- ◆ If security staff are available to walk you to your car, don't be embarrassed to ask for an escort. Most major malls offer this type of service.
- ◆ Check inside your car before getting in.
- ◆ If you leave your keys with a parking attendant or at a service station, leave only the car (not your house) key. If possible, leave a "valet" key (one that doesn't work on the trunk), and put your valuables in the trunk. Take your garage door opener, registration, and insurance card with you.
- ◆ Purchase or lease a cellular phone. Keep it charged or buy a cigarette lighter adapter for power and recharging.

---

## SECURITY AT HOME

- ◆ Know your neighbors and learn who can be called for assistance.
- ◆ Use only first initials and last names on mailboxes and in phone books.
- ◆ Change the locks when you move into a new residence.
- ◆ Don't hide spare keys outside. If you choose to do so, don't put them near the door. Make the hiding spot as obscure as possible, and don't tell anyone where it is.
- ◆ Check identification when repair people, salespeople, utility workers, or others come to the door. Don't hesitate to call and check them out or refuse entrance if something feels wrong or if they cannot provide proof of their identity.
- ◆ If you let someone in and have second thoughts, be assertive. Tell them to leave or leave yourself. Pretend you are not alone.
- ◆ Instruct children and babysitters not to give out information about who is home, who is out, or how long the situation will last.
- ◆ Don't leave notes on your door for others or allow solicitor's material to remain on your doorknob since they advertise your absence.
- ◆ If you suspect your home has been broken into, don't go in; go someplace else and call 911.
- ◆ Always lock doors when doing yard work or otherwise spending time in the yard. Keep your keys with you at all times. If you have a portable phone, take it with you.

## SECURITY ON THE STREET

- ◆ Stay on populated, well-lit streets. Avoid shrubbery, dark areas near buildings, and other places an attacker may hide. Avoid shortcuts through alleys, vacant lots, and other deserted places.
- ◆ Look around as you walk and be aware of your surroundings. Make it difficult for anyone to take you by surprise. Walk confidently at a steady pace, and make eye contact.
- ◆ Avoid secluded or deserted areas and businesses.
- ◆ Carry something that can make a loud noise that can scare off possible attackers.
- ◆ On public transportation, sit near the driver.
- ◆ If you have taken a ride in a cab or from a friend, ask the driver to wait and watch until you are safely inside your destination.
- ◆ Be cautious about revealing cash or credit cards.
- ◆ Try to limit the number of items you carry.
- ◆ If you carry a handbag, hold it close to your body with fastener closed and turned toward your body so a thief can't grab it and cause injury or knock you down. "Fanny packs" keep your personal items close to you while keeping your hands free. Be aware of where the zipper is and keep a close eye on it.
- ◆ Don't wear headphones. They block your ability to hear someone approach you.
- ◆ Trust your instincts, and don't hesitate to remove yourself from the situation. Be willing to make a scene or create a disturbance if necessary. Crimes such as rape are usually not committed by strangers, but by people who know their victims. Your safety may depend on a quick and decisive reaction.



# FRAUD PREVENTION

**P**ersonal security means more than just protecting your physical being; it also means protecting your identity. Criminals can steal your identity by taking personal, confidential information from your mail, from your wallet, even your computer. They may overhear you giving information to someone else on the phone. Your best protection is prevention.

## YOUR PERSONAL IDENTIFICATION NUMBER

Personal Identification Numbers (PIN) are used for credit cards, ATM cards, long distance calling cards, and other services.

- ◆ Your PIN should be memorized, secured and not given to anyone, not even family members or bank employees. The fewer people who have access to your PIN, the better.
- ◆ Never write your PIN on ATM or long distance calling cards. Don't write your PIN on a piece of paper and place it in your wallet.

## ATM CARDS

- ◆ For personal safety, remove the cash as soon as the ATM releases it. Put the cash in your pocket and wait until you are in a secure location before counting it.
- ◆ Never use an ATM in an isolated area or where people are loitering. Avoid ATMs that have poor lighting around them.
- ◆ Never leave the receipt at the site. Dishonest people can use your receipt to get your account number.



Consider buying a shredder for all documents with personal information.

- ◆ If you deposit money in an ATM, be sure the envelope fully drops into the machine. Never give the money to a person who promises to make the deposit for you.

## PROTECT YOUR MAIL

Follow these steps to make it harder for thieves to steal your mail.

- ◆ Never send cash or coins in the mail. Use checks or money orders.
- ◆ Don't leave mail in your mailbox.
- ◆ Have your local post office hold your mail while you are on vacation or absent from your home.
- ◆ If you do not receive valuable mail you are expecting, contact the issuing agency immediately.
- ◆ Notify your post office and others if you change your address.
- ◆ Always put your mail in a Postal Service mail collection box or mail slot at your local post office, or hand your mail to your letter carrier. Never place your outgoing mail in an unprotected mailbox, or into a collection box after the last scheduled pick up.

If you believe your mail has been stolen, report it immediately to your local Sheriff's Office precinct or storefront, or the Police Department.

---

## YOUR CREDIT CARDS

- ◆ Only give your credit card account number to make a purchase or reservation that you have initiated. Never give personal information over a cellular phone.
- ◆ Watch your credit card after giving it to store clerks to protect against extra imprints being made.
- ◆ Destroy all carbons after you make a purchase (do not discard them in the trash can at the purchase counter). Keep charge slips in a safe place.



- ◆ Save all receipts, and compare them to your monthly statement. Report any discrepancies immediately!
- ◆ Keep a master list in a secure place at home with all account numbers and phone numbers for reporting stolen or lost cards. Keep another copy in a safe deposit box.

### Lost or Stolen Cards

- ◆ Always report lost or stolen cards to the issuing company immediately. This limits any unauthorized use of your card and permits the company to issue a new card. Please note that protections on credit cards may not apply to debit cards. Read your cardholder agreement.

## COMPUTER INFORMATION AND THE INTERNET

Increasingly, we rely on computers to store and send confidential, personal information. Like a home, computers need to be secured against intruders.

### Passwords

Passwords are your first line of defense against potential computer intruders. The worst passwords to use are the ones that are obvious: your first name, spouse's name, maiden name, pets, children's name, even street addresses. The best passwords mix numbers, punctuation, and upper and lowercase letters. A password that is not found in the dictionary is even better. Programs exist that will try every word in the dictionary in an effort to crack your security.

Few people should have access to your codes and passwords. Protect your passwords by changing them regularly and memorizing them: never write them down! Never store passwords on your computer or at a web site; anyone who uses your machine will have access to information that is password protected.

### Encryption: A Second Line of Defense

Encryption software "scrambles" files so they are unreadable to anyone who does not have the encryption key. Use encryption software to store important personal, financial, and security files on your computer.

### Did You Really Erase That File?

Files that are deleted or erased by the user can be resurrected or recreated. Many law enforcement officials use this knowledge to fight crime; someone else could use it to commit crimes.

Do a complete "Security Erase" on your computer before you sell it or donate it. If you don't know how to do this, ask someone who does or have a shop do it for you.

### Be Wary on the Internet

When you use computer, internet, or on-line services, be cautious about providing personal information. Be sure you know exactly what information about you can be accessed by other users. Finally, talk to your children and warn them never to give personal information to anyone on the Internet.

